

INSTALLATION MANUAL

English Edition

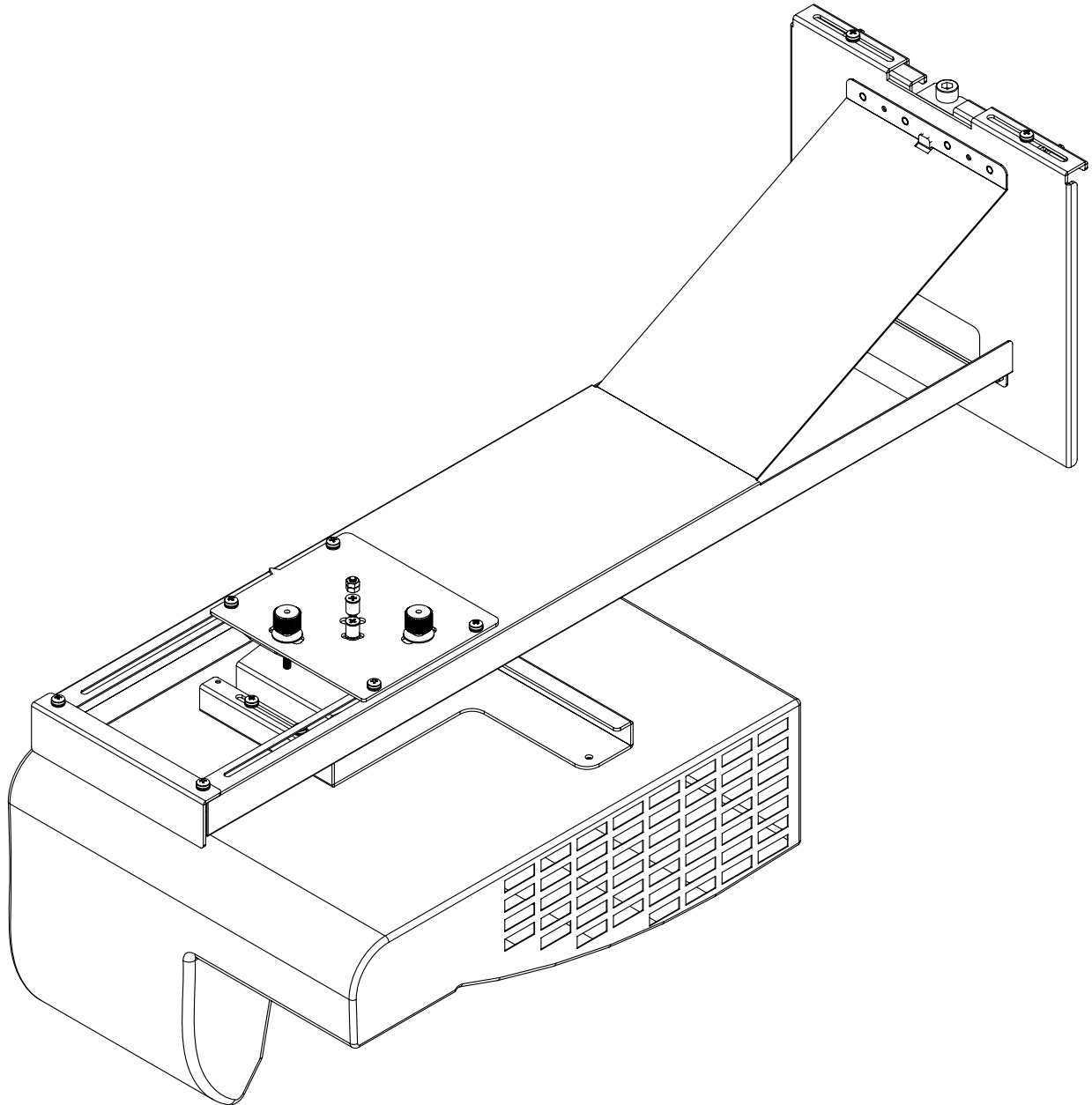

D75X ULTRA SHORT SERIES





SAFETY INSTRUCTION

For your safety, please read the instruction before using the wall mount bracket. Any improper disposition caused by ignoring this manual may damage the hanger frame and result in personal injury and property damage. Please keep the manual properly for future reference.









Please read the installation manual and safety instruction of the projector that matches our wall mount bracket and operate according to the instruction.

SYMBOL INSTRUCTION

In order to avoid personal injury and property damage, the following warning symbols are used in this setting manual. Please make sure that you have understood all these warning symbols while reading this instruction.

 WARNING	Ignoring this signal may lead to improper handling and result in personal injury, even death.
 CAUTION	Ignoring this signal may lead to improper handling and result in personal injury or machine damage.
	Useful messages.
	Compulsory operations that must be conducted.
	Recommended operations that should be conducted.

SAFETY PROTECTION MEASURES FOR SETTING

 WARNING	
The wall mounted bracket is designed for installation of projector on walls. The weight of the installation object other than the designed projector may damage the wall mounted bracket, and if the wall mounted bracket falls, personal injury and property damage may happen.	
Installation (wall installation) should be performed by specialists who have technical knowledge and ability. Incomplete or improper installation may cause wall mounted bracket to fall, resulting in personal injury or property damage.	
Please install the wall mounted bracket according to this instruction. Otherwise, the wall mounted bracket may fall and result in personal injury or an accident.	
Operating power cord with care. Improper operation could cause fire or electric shock. Please comply with the following requirements while operating: 1: Do not operate the power plug when your hands are wet. 2: Do not use damaged and changed power cord. 3: Do not employ excessive force while pulling power cord when it passes through the wall mount bracket.	
If the position of installation of the wall mounted bracket is prone to be affected by vibration and impact, please do not install the wall mounted bracket. Vibration and impact may damage the projector and the installation plate, or even may result in the wall mounted bracket and projector falling, resulting injury of people and damage of property.	
Talling the wall mount bracket, please adopt methods that can support the projector and wall mount bracket as well as to eliminate any vibration from the horizontal level. M8 nut and screw should be applied. Nut and screw that are less than 8M may lead to hanger falling. DELTA is disclaim from the responsible for any loss and damage caused by insufficient holding strength of the wall or improper installation.	
The installation should be conducted by two qualified person concurrently. If it is necessary to unscrew any nuts, please take care that the wall mounted bracket does not fall. If the hanger or the projector falls, personal injury or property loss may occur.	

 **WARNING**

If the wall mounted bracket is meant for installation of the projector on walls and the wall should be strong enough to hold the projector and wall mounted bracket.

The wall mounted bracket should be installed on concrete walls. The quality of projector and hanger should be qualified before installation, and the strength of walls should be verified and maintained. If the strength of walls is not strong enough, please strengthen them before installation.



Please test the wall mounted bracket at regular intervals so as to make sure that there are no broken parts or loose screws. If any broken part is found, please refrain from using the wall mounted bracket. If the wall mounted bracket or projector falls, personal injury or property loss may occur.



Please do not with or modify the wall mounted bracket.



Please do not hang up the wall mounted bracket or hang things on the wall mounted bracket. If the projector or the wall mounted bracket falls, personal injury or property loss may occur.



Glues lubricant or oil should not be used to wall mounted bracket can chemical attack which could result in a rupture of the wall mounted bracket and then cause the projector to fall. As a result, personal injury or property loss may occur.



Please tighten all the nuts and screws after adjustment. Otherwise, the projector or hanger may fall and lead to personal injury or property loss.



Please refrain from loosening the nuts and screw after installation, unless otherwise deemed necessary and performed by qualified specialists who have technical knowledge and ability.

Please test the wall mounted bracket at a regular interval to ensure the nuts and screw are tight. If the nuts and screws are found loose, please tighten them, otherwise, the projector or the wall mounted bracket may fall and cause personal injury and property loss.



 **CAUTION**

Please do not install the hanger frame in places where the temperature could be higher than that the projector's maximum sustainable temperature, because the exceeding high temperature may damage the projector.



Please avoid installing the wall mounted bracket in places that is too wet or too dusty so that lens and optical components can be protected from being contaminated.



While adjusting wall mounted bracket, please do not employ excessive force because the wall mounted bracket may break and cause personal injury.



Only professional person can dismantle or reset the projector (including maintaining and overhauling). Please consult the relevant information as illustrated in the instructions.



THE LOCATION FOR WALL MOUNTED BRACKET

- 1: Conducting power routing in advance in the position where the hanger frame is installed.
- 2: The position should be away from other electrical equipments, such as fluorescent lamps and air condition. Some fluorescent lamps may cause interference signal to the projector's remote control.
- 3: The length of connecting power cord should be less than 20 meters so as to reduce noise interference.
- 4: Plug-in screen or flat screen is suggested.
- 5: When using interactive function, please make sure to set the projector under the following condition,
 - (1): Projection screen is rectangle in shape with no distortion.
 - (2): The vertical and horizontal angle between projector and the projection screen should be less than 3 degree comparing to the projector screen.
 - (3): The horizontal and vertical keystone correction should be less than 5 degree while using keystone correction,

ABOUT THIS INSTALLATION INSTRUCTION

This instruction introduces how to use customized wall mounted bracket to install D75 ultra short throw projector on walls. The unit of measurement for all sizes mark place in this instruction is in "mm".

1 PACKAGING ITEMS

P. 4

2 SPECIFICATIONS

P. 5

3 PROJECTION DISTANCE CHART

P. 7

4 INSTALLATION STEPS FOR WALL MOUNTED BRACKET P. 9

- (1): Dismantle parts
- (2): Verify the strength of walls, installation environment, installation position and drill holes on the walls.
- (3): Install hanger frame on walls.
- (4): Verify the distance of the projector. Move the three axis fine-tuner to proper position according to the projector distance chart.
- (5): Power cord should pass through the hanger frame.
- (6): Adjust the slider plate up and down to align to the standard position.
- (7): Install the projector onto the hanger frame.
- (8): Connect the power cord and other electrical cables to the projector.

5 ADJUSTING STEPS OF PROJECTOR IMAGE

P. 13

- (1) Switch on the projector
- (2) Adjust the aspect ratio
- (3) Display the test image
- (4) Adjust the left and right alignment position
- (5) Adjust the up and down rotation
- (6) Adjust the left and right rotation
- (7) Adjust the keystone
- (8) Adjust the image size
- (9) Adjust the image up and down
- (10) Switch off the testing image display

HARDWARES INCLUDED

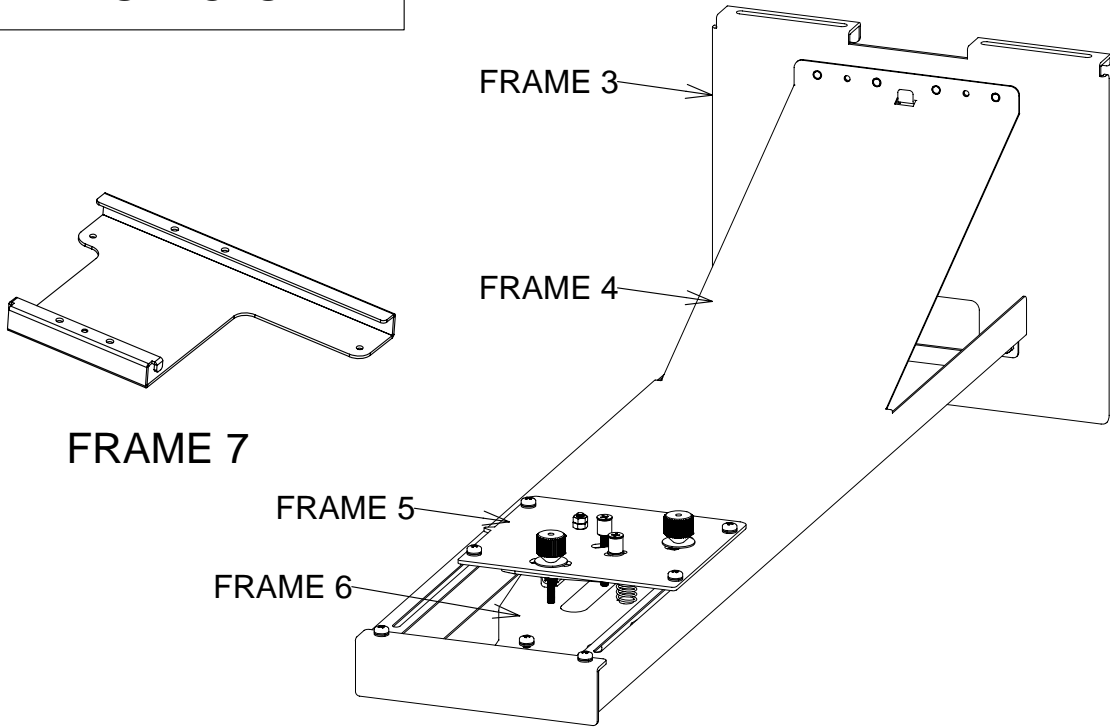

TRI-AXIS FINE-TUNING COMPONENTS

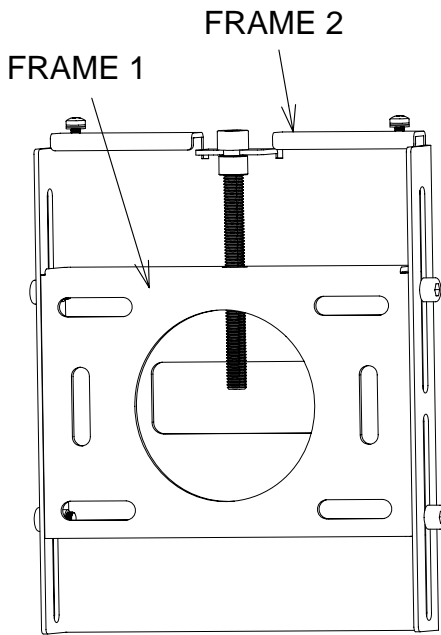

D75X ULTRA SHORT SERIES (BRACKET 1) SETTING DRILLING PAPER (1:1)

114

D751ST XGA 0.43				
SN	Screen size		H1 Vertical distance	
	inch	mm(diagonal)	inch	mm
1	68	1727	11.86	328.5
2	75	1905	12.88	354.4
3	77	1956	13.18	361.4
4	78	1987	13.18	362
5	80	2032	13.60	372.6
6	82	2083	13.90	380.2
7	85	2159	14.32	390.9

D755WT WXGA 0.35				
SN	Screen size		H1 Vertical distance	
	inch	mm(diagonal)	inch	mm
1	80	2032	11.02	307.2
2	85	2159	11.59	321.5
3	87	2210	11.82	327.4
4	90	2286	12.16	336.1
5	92	2337	12.38	341.6
6	95	2413	12.72	350.2
7	97	2464	12.95	356.1
8	100	2540	13.26	364.1

Description:
 1: "A" is the drill location. Please review the description in manual page 9.
 2: This screenshot is only for D751ST XGA 0.43/ WXGA 0.35 hanger.
 3: The scale in the screenshot for all indicated location is 1:1.

PART LIST

D75X INSTALLATION (FRAME 1) SETTING DRILLING PAPER (1:1)

Screen shot	Hardware Specifications	Qty	Purpose
	M4*10mm ball head cross head screw (with flat gasket and spring washer)	3 (pcs)	Used for connecting wall mounted bracket structure # 7 with projector
	M8*70mm setscrew (with nut, flat gasket and spring washer)	4 (pcs)	Used for installing and fixing wall mounted bracket structure #1 onto the wall

1: Please follow the instructions in the manual and install with the attached hardware.

2: Please prepare the required tools and hardware before installation

SPECIFICATION

Item	Spec	Description	Remark
Gross mass of hanger frame	About 4.72kg	The three axis fine-tuning components(2.82kg), wall fixture hardwares(0.86kg), independent components packed seperately (0.12kg).	
Maximum load capacity	30kg	Not inclusive of wall mounted bracket's weight.	
The left and right adjusting range	±40mm	Frame structure # 3 adjustable by 30mm, frame structure # 7 adjustable by ±10mm.	P. 13
The up and down rotation adjusting range	±5°	The three axis fine-tuner does horizontal scrolling adjustment	P. 14
The left and right rotation adjusting range	±5°	The three axis fine-tuner does horizontal rotating adjustment	P. 15
Keystone adjusting range	±5°	The three axis fine-tuner does vertical scrolling adjustment	P. 16
Forward and backward adjustment by range	Can be adjusted 120mm forward		P. 17
Up and down adjustment by range	±40mm		P. 18

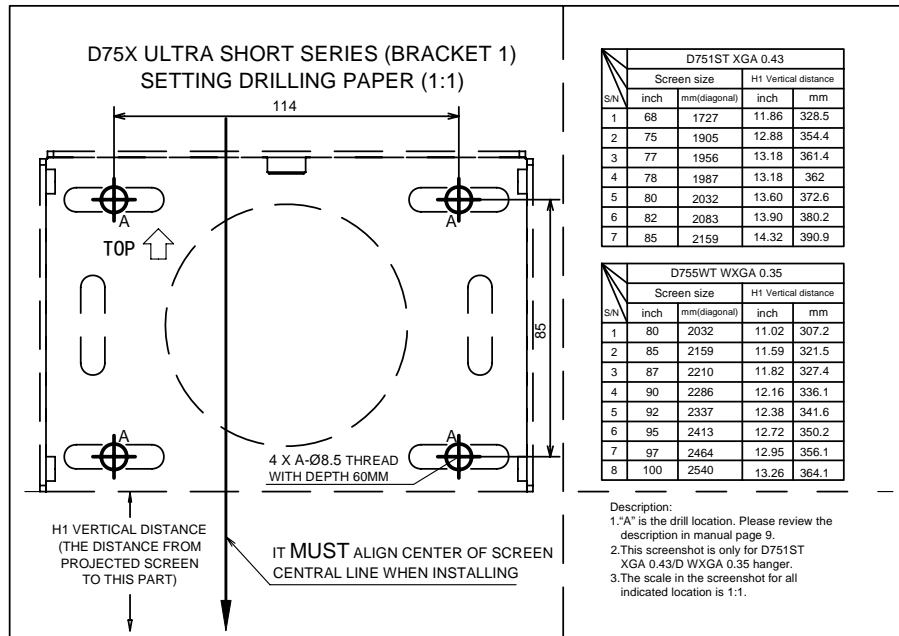

D75X INSTALLATION (FRAME 1) SETTING DRILLING PAPER (1:1)

SCREENSHOT OF PROJECT DISTANCE

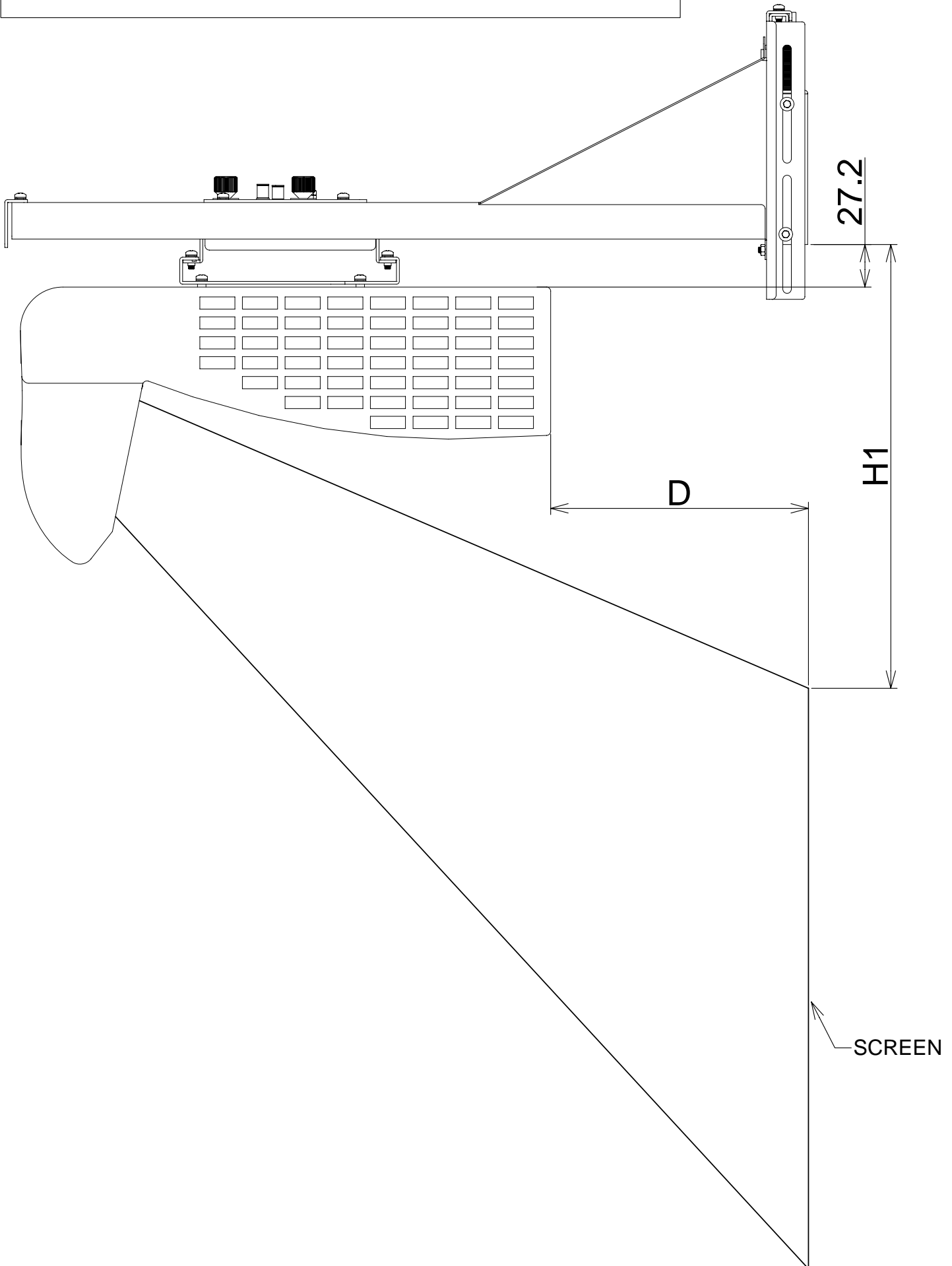

PROJECT DISTANCE

D751ST XGA 0.43									
Screen size (diagonal)		Screen width		Screen height		Projecting distance (D)		Vertical distance (H1)	
inch	mm	inch	mm	inch	mm	inch	mm	inch	mm
68	1727	54	1382	40	1036	11.16	283.4	11.86	328.5
75	1905	59	1524	45	1143	13.83	351.4	12.88	354.4
77	1956	61	1565	46	1173	14.62	371.4	13.18	361.4
78	1987	61	1566	46	1175	14.62	371.4	13.18	362
80	2032	63	1626	48	1219	15.72	399.4	13.60	372.6
82	2083	65	1666	49	1250	16.51	419.4	13.90	380.2
85	2159	67	1727	51	1295	17.61	447.4	14.32	390.9

D755WT WXGA 0.35									
Screen size (diagonal)		Screen width		Screen height		Projecting distance (D)		Vertical distance (H1)	
inch	mm	inch	mm	inch	mm	inch	mm	inch	mm
80	2032	67	1723	42	1077	11.11	282.3	11.02	307.2
85	2159	71	1831	45	1144	12.73	323.3	11.59	321.5
87	2210	73	1874	46	1171	13.40	340.3	11.82	327.4
90	2286	76	1939	47	1212	14.38	365.3	12.16	336.1
92	2337	77	1982	48	1239	15.01	381.3	12.38	341.6
95	2413	80	2046	50	1279	15.98	405.8	12.72	350.2
97	2464	81	2089	51	1306	16.65	422.8	12.95	356.1
100	2540	85	2154	53	1346	17.55	445.8	13.26	364.1

ASSEMBLY BREAKDOWN DIAGRAM

Quick Installation Steps:

- Step 1: frame #1 setting drilling paper of ultra short series (1:1) to the proper position in up screen (see details please refer to P.9). Perforate the setting wall. (percussion drill and drill 8.5, 60mm depth)
- Step 2: Install M8*70 setscrew in the wall's hole.
- Step 3: Use M8*70 setscrew (4X) fix structure frame # 1 to the wall's hole.
- Step 4: Install structure frame # 2 on structure frame # 1 (see P.10), switch it to intermediate position and use screw B (M4*10 up and down adjusting fixing screw) to lock it yet.
- Step 5: Loosen screw "C", decline structure frame # 3 by 5 degree to aim at the positioning peg, and position the slider structure into structure frame # 2's slide-way. Adjust the slide-way to intermediate position and tighten the screw "C" into structure frame # 2 's threaded hole, but do not lock it. When the positioning is in place, tighten the screw "C". (see details please refer to P.11)
- Step 6: Use "I" screw to connect structure frame # 7 and projector. Fix them, and install them on structure frame # 6. After adjusting structure frame # 7 to a proper position, lock screw "H". (see P.12)

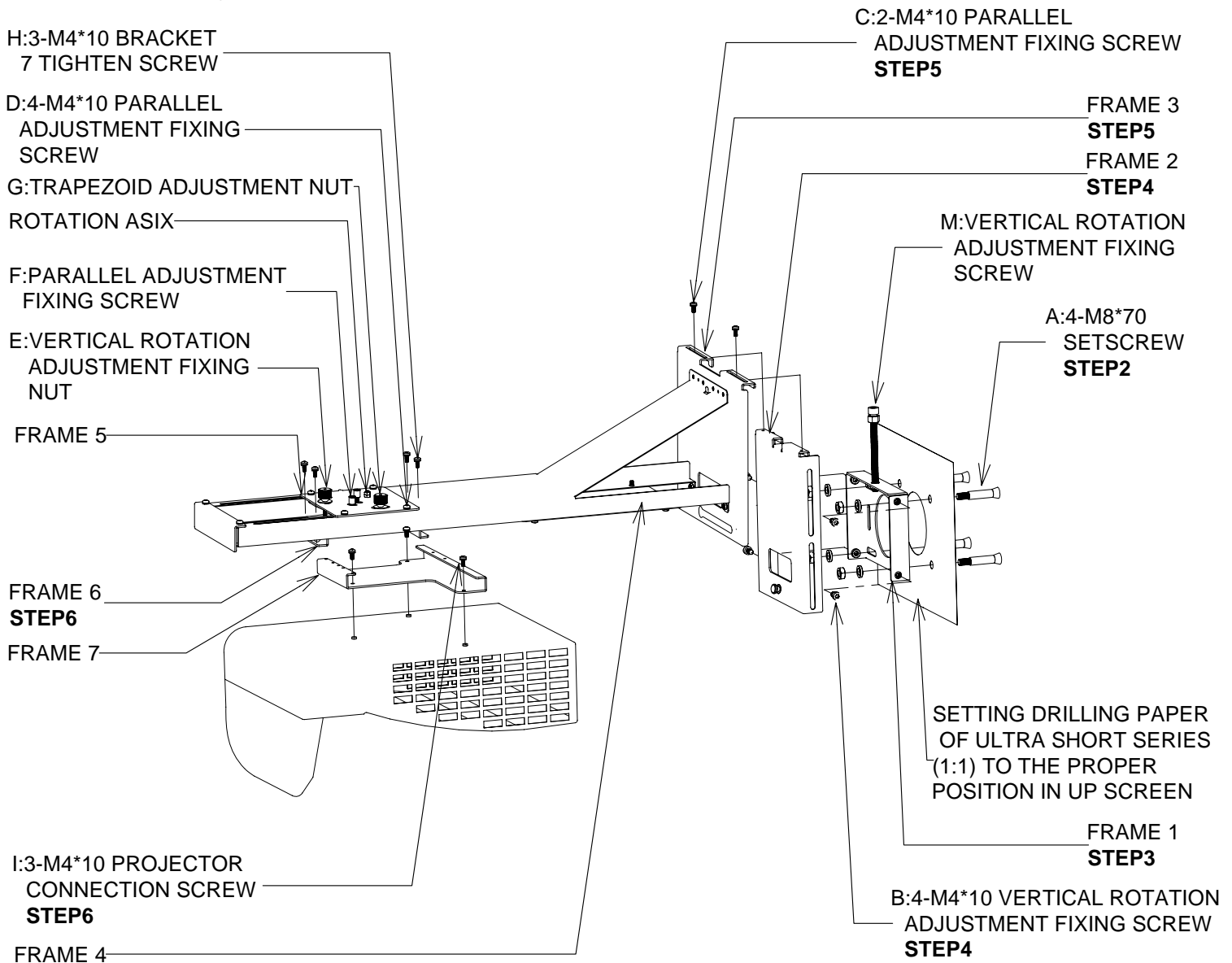

INSTALLING STEP 1

Installing steps of holder 1:

- 1: Ensure the projector image allies with the center line of the screen, and determine the corresponding vertical distance value (H1) according to the projector distance chart.
- 2: Use D79X setting perforating paper of ultra short throw series (1:1) to determine the corresponding vertical distance.(H2) = (H1)-27.2mm
- 3: Fix the D79X setting perforating paper of ultra short throw series (1:1) and drill the wall according to the hole position on paper.(see picture 1).
- 4: Drive the attached setscrew (4-M8*70mm) in the corresponding wall's hole.
- 5: Loosen screw "B" (4-M4*10), and dismantle the setting wall components. (structure frame # 1 and structure frame # 2)
- 6: Install the structure frame # 1 and tighten the screw (see picture 2) to ensure that the installation is correct and reliable.

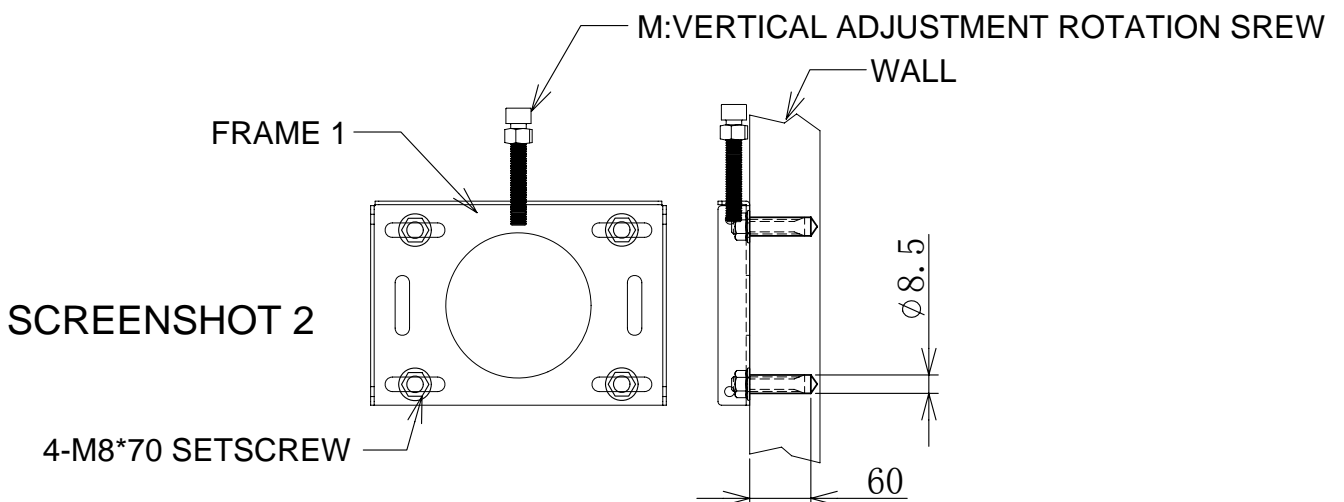
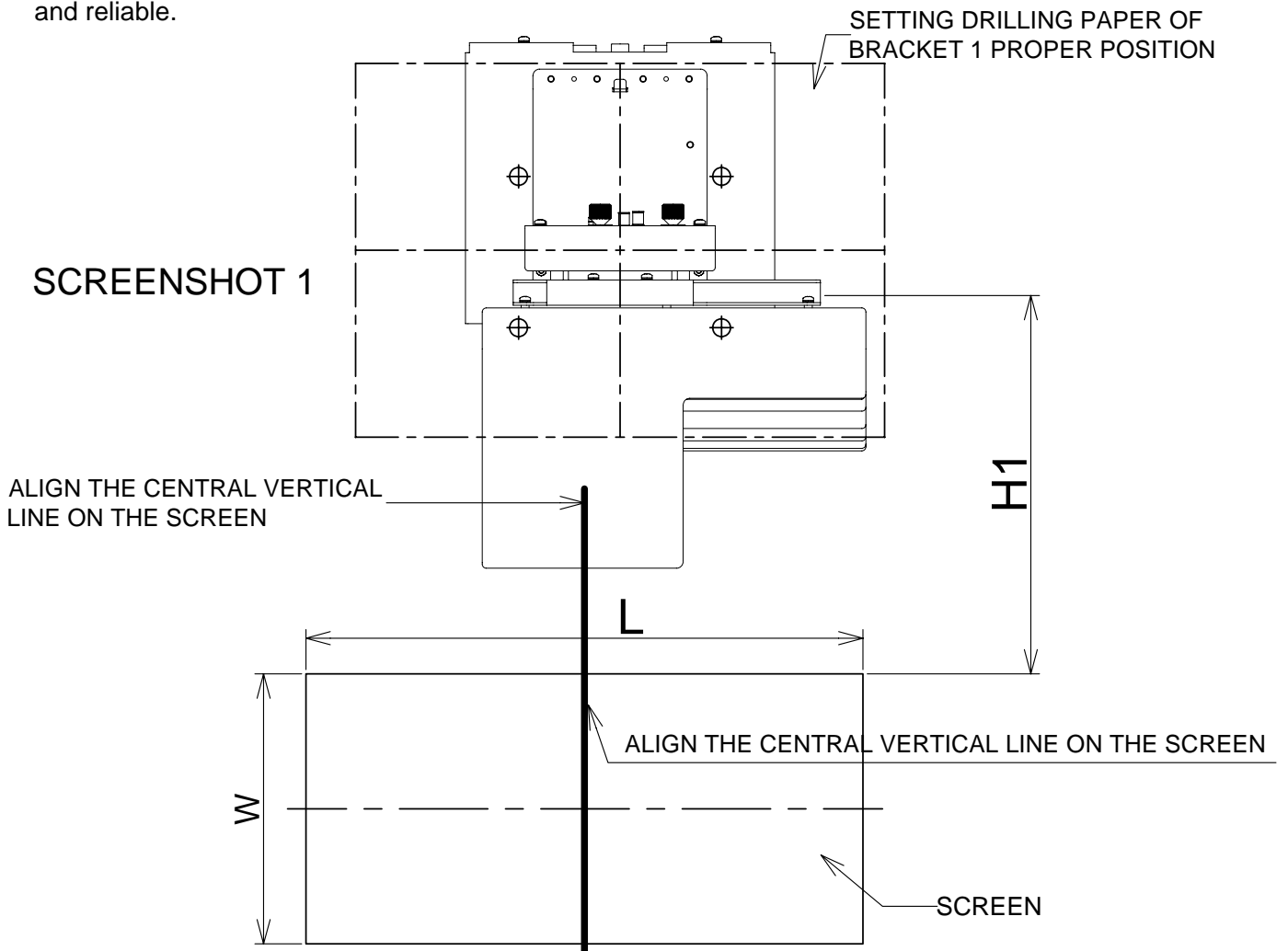

INSTALLING STEP 2

Installing steps of structure frame # 2:

- 1: Place structure frame # 2's neck into structure frame # 1's up and down adjusting screw inserts.
- 2: Screw "B" screw (M4*10mm) into structure frame # 1's corresponding threaded hole slightly. (2 PCS of both left and right side).
- 3: Use up and down adjusting screw to adjust structure frame # 2 to proper position, and tighten the screw "B". (4-M4*10mm)

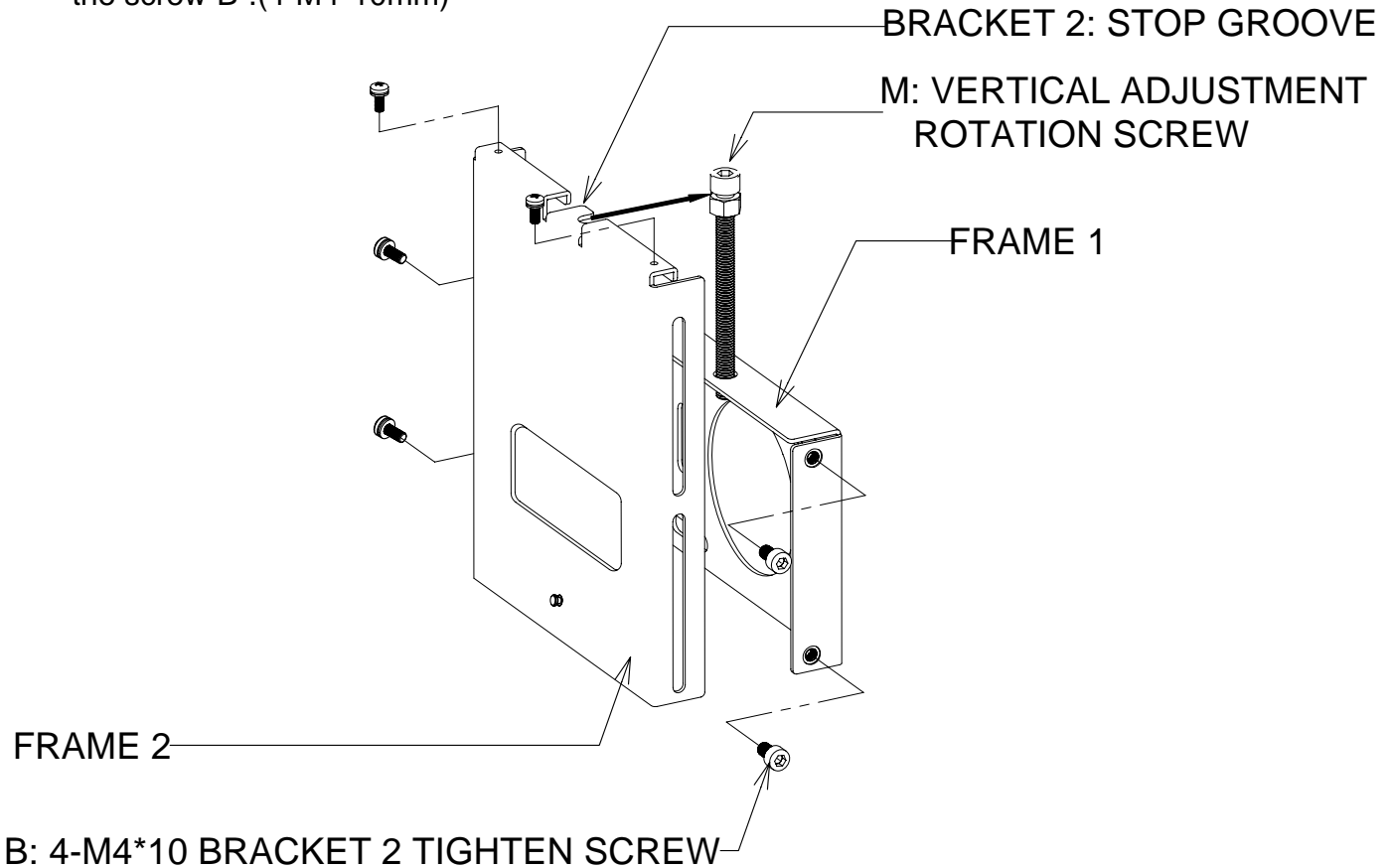

BEFORE INSTALLATION

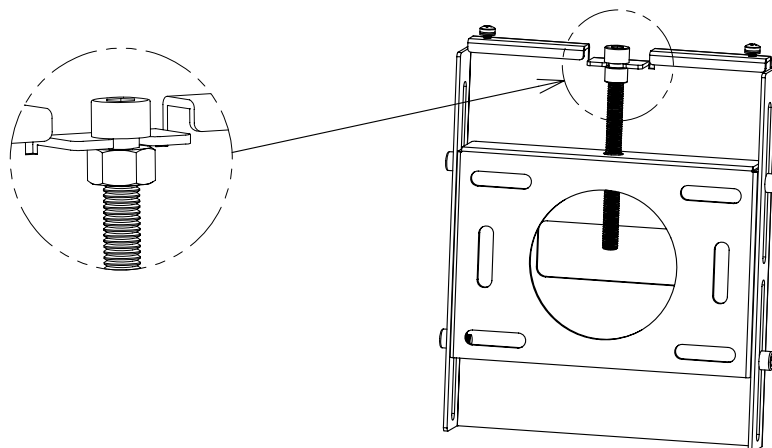

AFTER INSTALLATION

INSTALLING STEP 3

Installing steps of structure frame # 2:

- 1: Loosen "C" screw. (2-M4*10mm)
- 2: Decline the three axis fine-tuner by 5 degree to aim at the registration mast. As illustrated in the following picture 2, install the slide-way on structure frame # 2's slide-way, and switch it to intermediate position.
- 3: Tighten screw "C" (2-M4-10mm) into structure frame # 2's corresponding threaded hole slightly, do not lock it.
- 4: Adjust the screw "C" to proper position and tighten it. (2-M4*10mm)

C: 2-M4*10 PARALLEL ADJUSTMENT FIXING SCREW

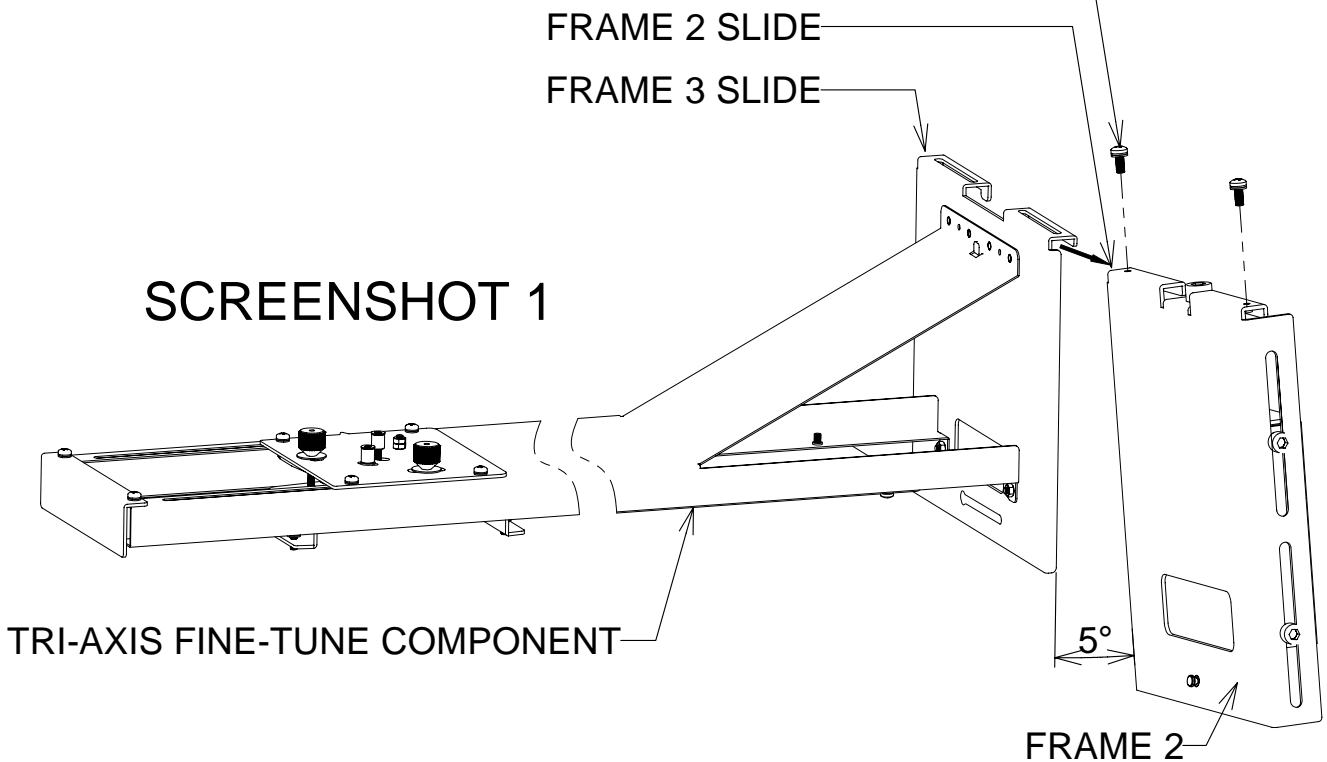

BEFORE INSTALLATION

SCREENSHOT 2

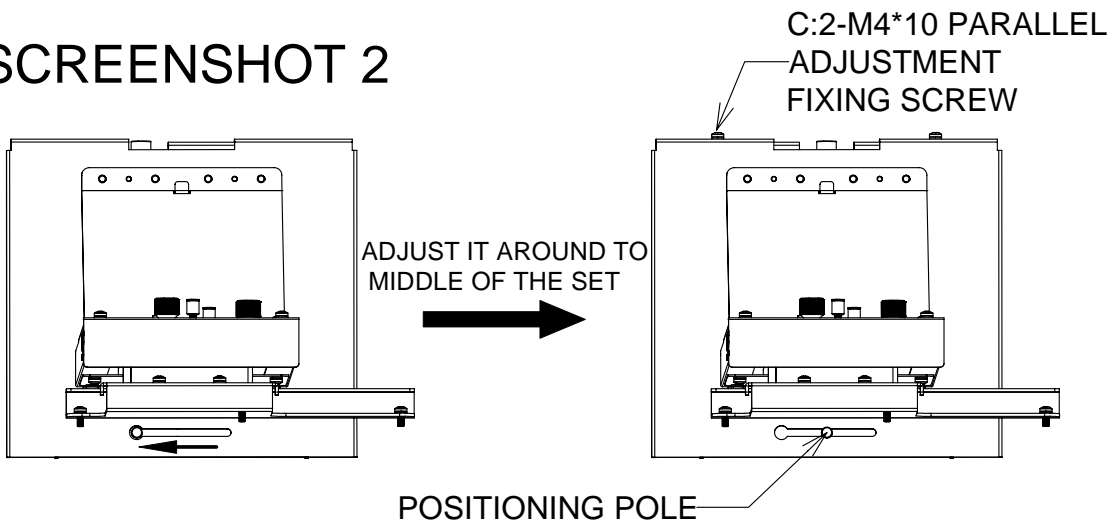

AFTER INSTALLATION

INSTALLING STEP 4

Installing steps of projector:

- 1: Loosen screw "H" (4X-M4*10), and remove structure frame # 7.
- 2: Use "I" screw (3-M4*10mm) to connect structure frame # 7 and projector, and assemble them together.
- 3: Assemble the connected structure frame # 7 and projector on structure frame # 6.
- 4: Tighten screw "H"(4-M4*10mm) into structure frame # 6's corresponding threaded hole slightly, not locked.
- 5: Slide structure frame # 7 to proper position, and tighten screw "H". (4-M4*10mm)

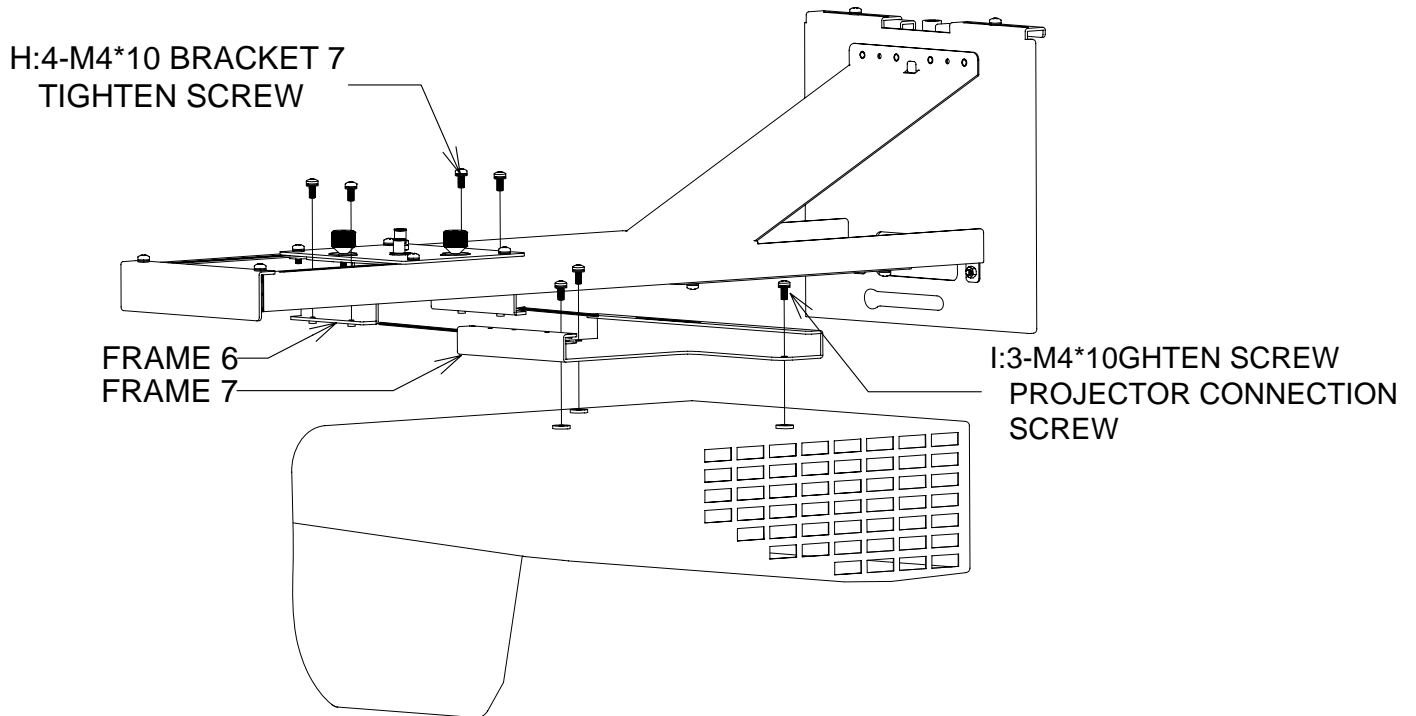

BEFORE INSTALLATION

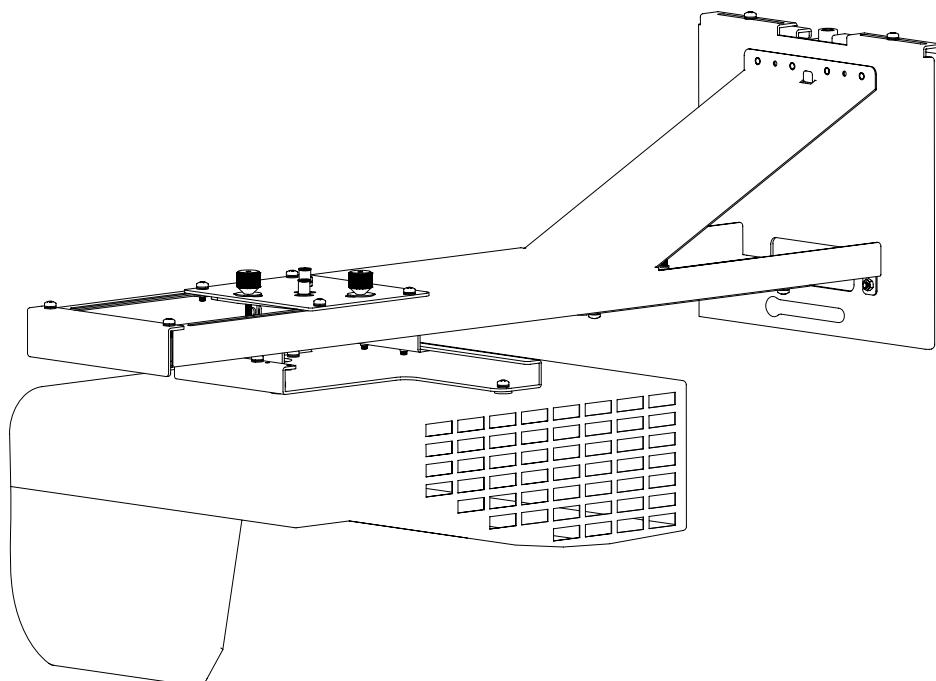

AFTER INSTALLATION

ADJUSTING STEP 1

Instruction of left and right adjusting movement:

- 1: Loosen screw "C" (2-M4*10mm), slightly.
- 2: Push structure frame # 3 left or right directly to conduct adjustment.
- 3: Adjust screw "C" to the proper position (X axis direction), and lock it. (2-M4*10mm)
- 4: The maximum adjustable distance is $\pm 30\text{mm}$.

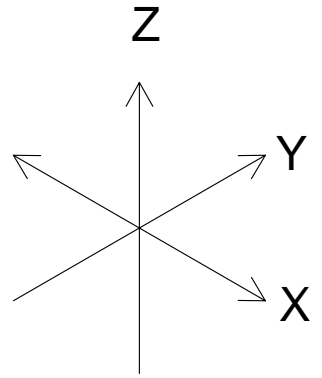

C: 2-M4*10 PARALLEL ROTATION
TIGHTEN SCREW

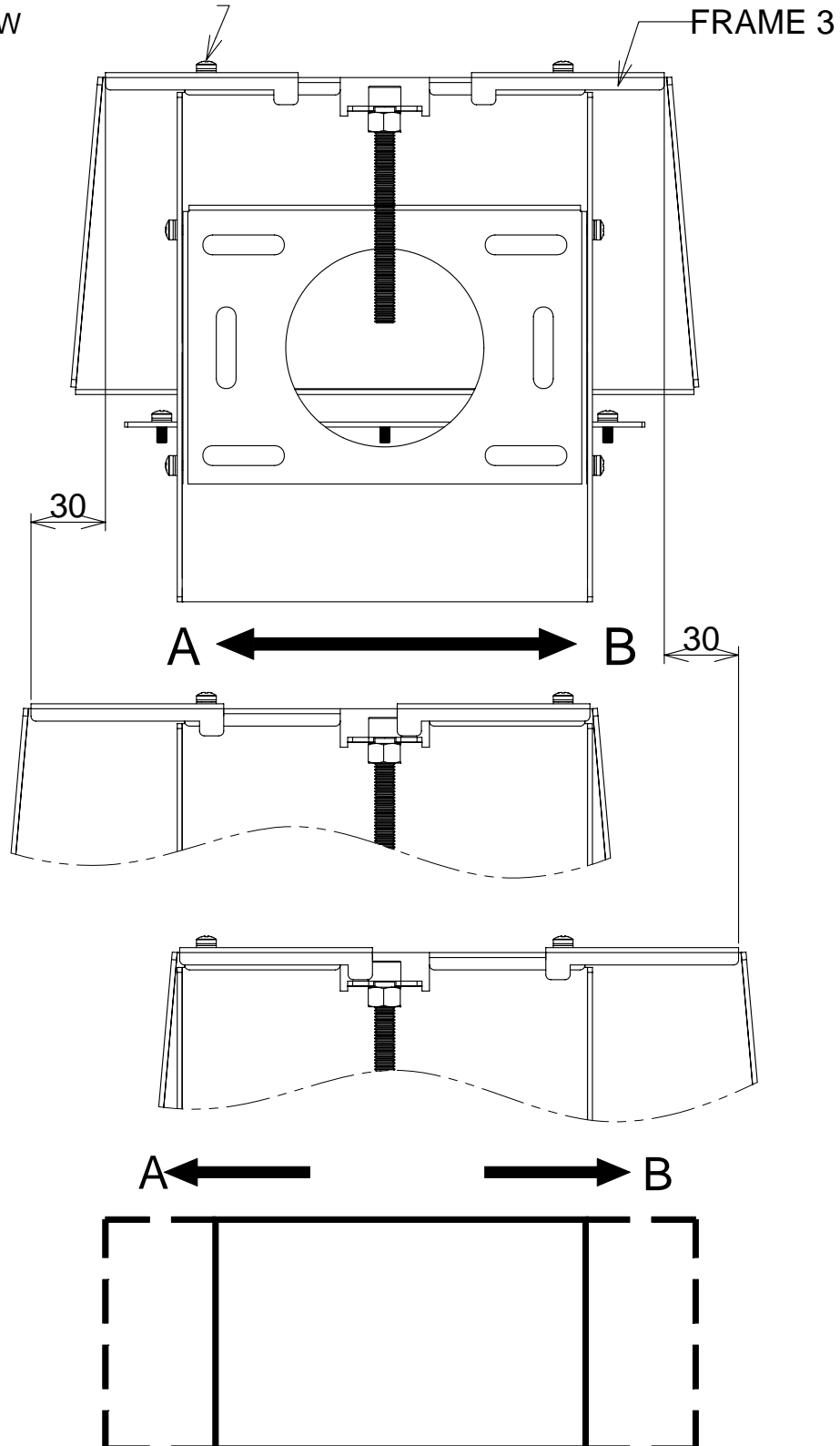

ADJUSTING STEP 2

Instruction of up and down rotation movement:

- 1: Tuner "E" does clockwise movements and its function is to adjust structure frame # 6 to drive projector into clockwise (X axis direction) rotation adjustment.(picture A)
- 2: Tuner "E" does anti-clockwise movements and its function is to adjust structure frame # 6 to drive projector into anti-clockwise (X axis direction) rotation adjustment.(picture B)
- 3: The maximum adjustable angle is ± 5 degree.

E:VERTICAL ROTATION
ADJUSTMENT NUT

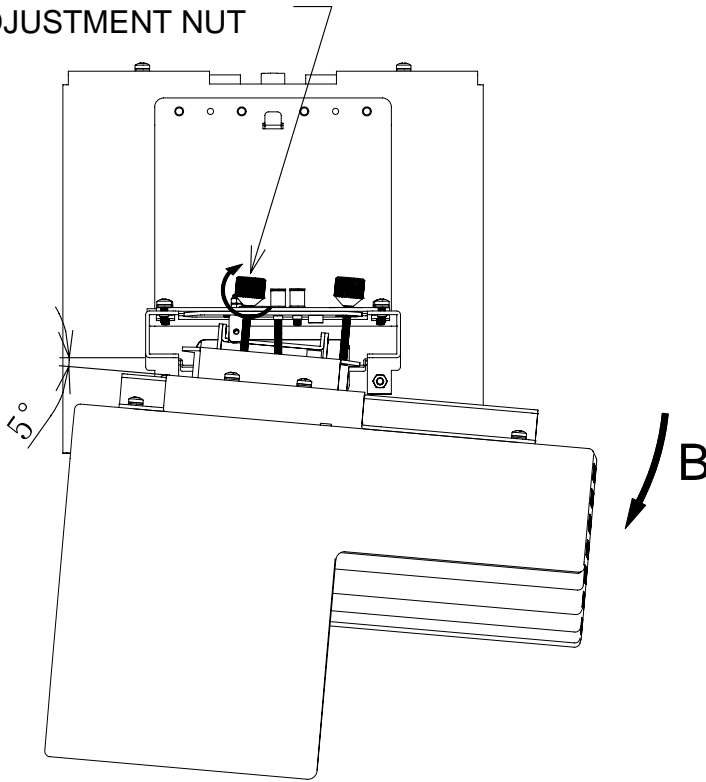

SCREENSHOT A

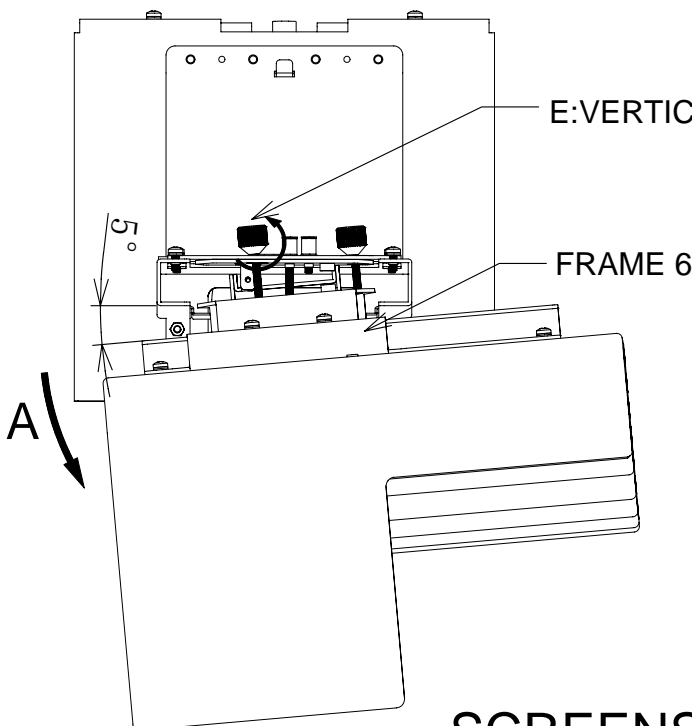
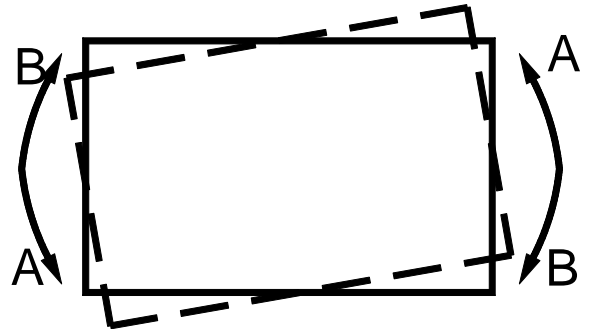
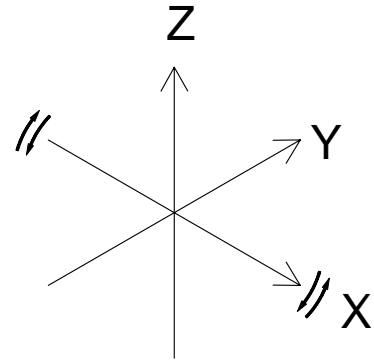

SCREENSHOT B

ADJUSTING STEP 3

Instruction of left and right rotation movement:

- 1: Screw "F" for and rotate axis nut slightly.
- 2: Take the rotation axis as the axis (Z axis), adjust the setting disc through horizontal left and right rotation so that structure frame # 7 can drive projector towards horizontal rotation.(Z axis direction).
- 3: When the horizontal rotation position is adjusted to a proper position, tighten the screw "F".
- 4: When the three axis are adjusted to proper positions, tighten the rotation axis nut.

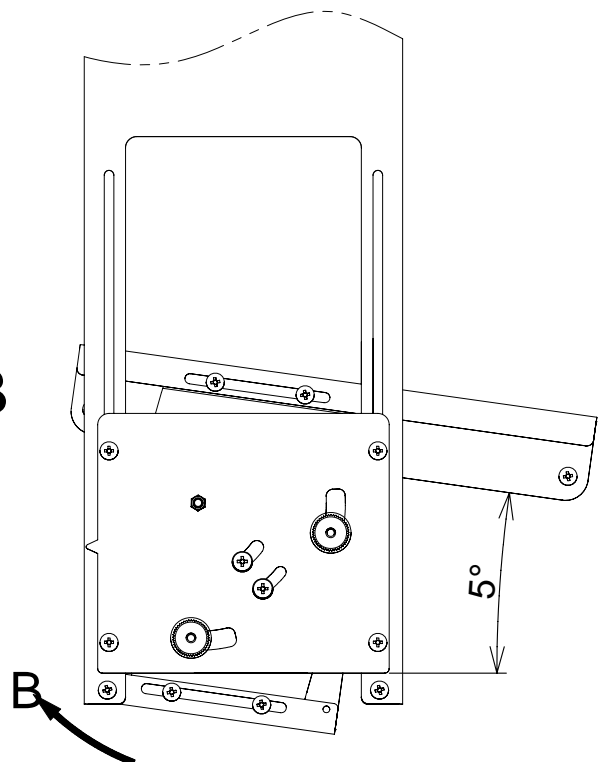
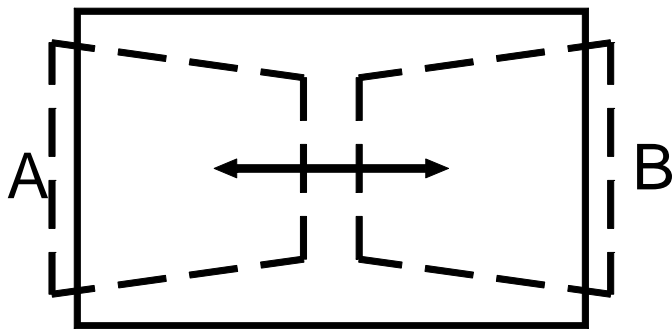
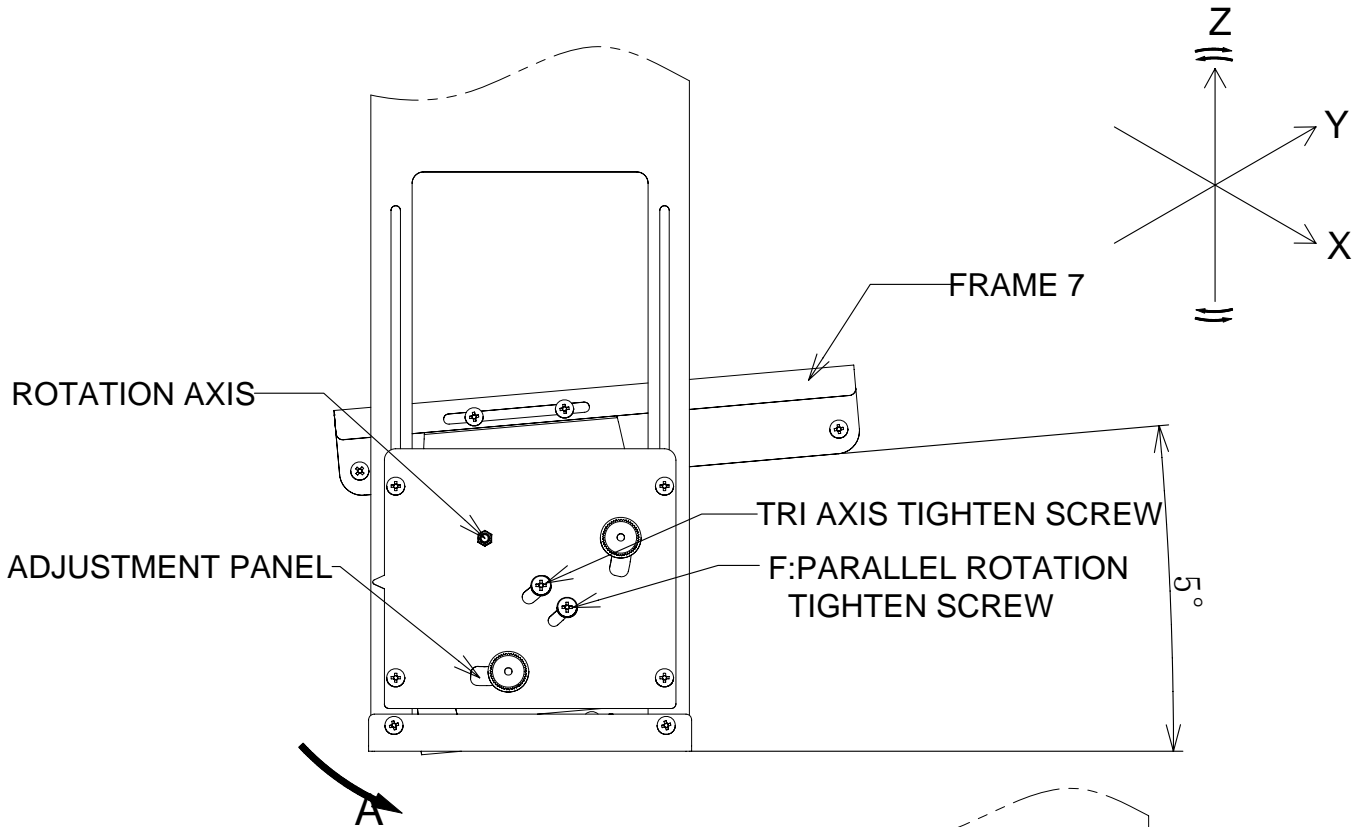

ADJUSTING STEP 4

Instruction of keystone adjustment movement:

- 1: Tuner "G" does clockwise movements and it's function is to move structure frame # 6 to drive projector towards a clockwise (Y axis direction) rotation adjustment.(picture D)
- 2: Tuner "G" does anti-clockwise movements and it's function is to move structure frame # 6 drive projector towards an anti-clockwise (Y axis direction) rotation adjustment.(picture C)
- 3: The maximum adjustable angle is ± 5 degree.

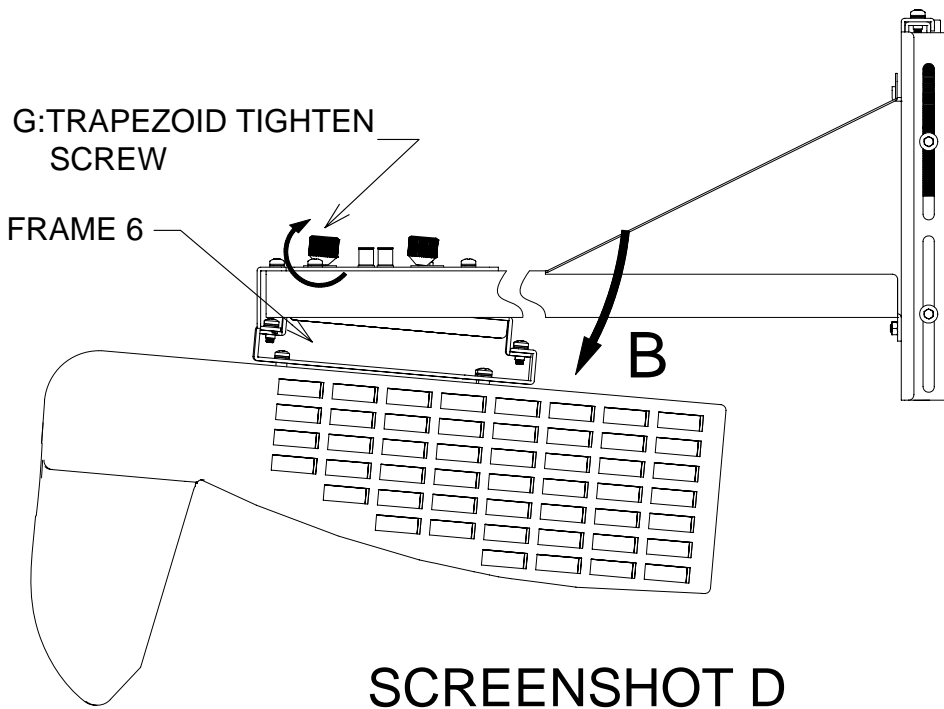
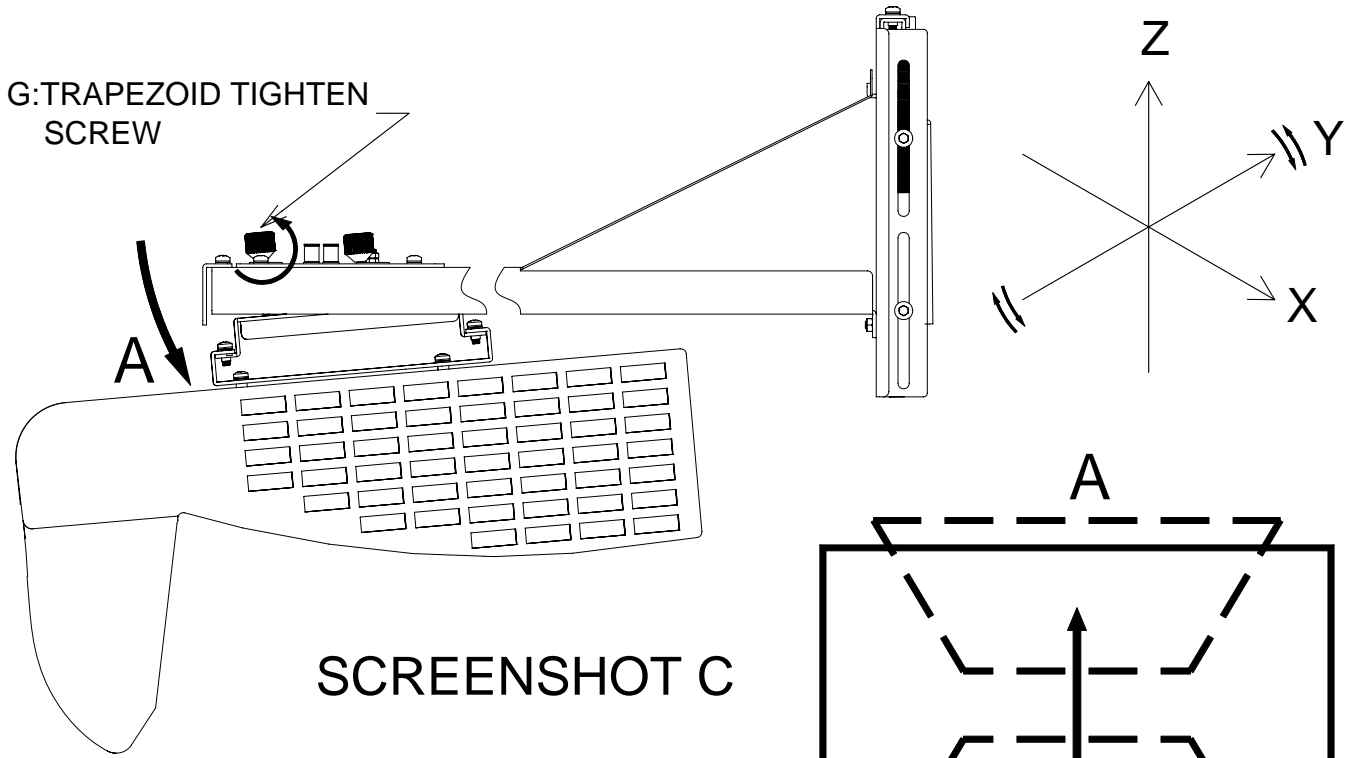

ADJUSTING STEP 5

Instruction of image size adjustment movement:

- 1: Loosen screw "D" (4-M4*10mm) slightly. Move structure frame # 5 forward and backward to adjust its position in Y axis.
- 2: For the distance between screen and projector, please refer to the projector sheet.(P. 7)
- 3: When the image size is OK, please tighten screw "D". (4-M4*10mm)
- 4: The maximum adjustable distance is 120mm.

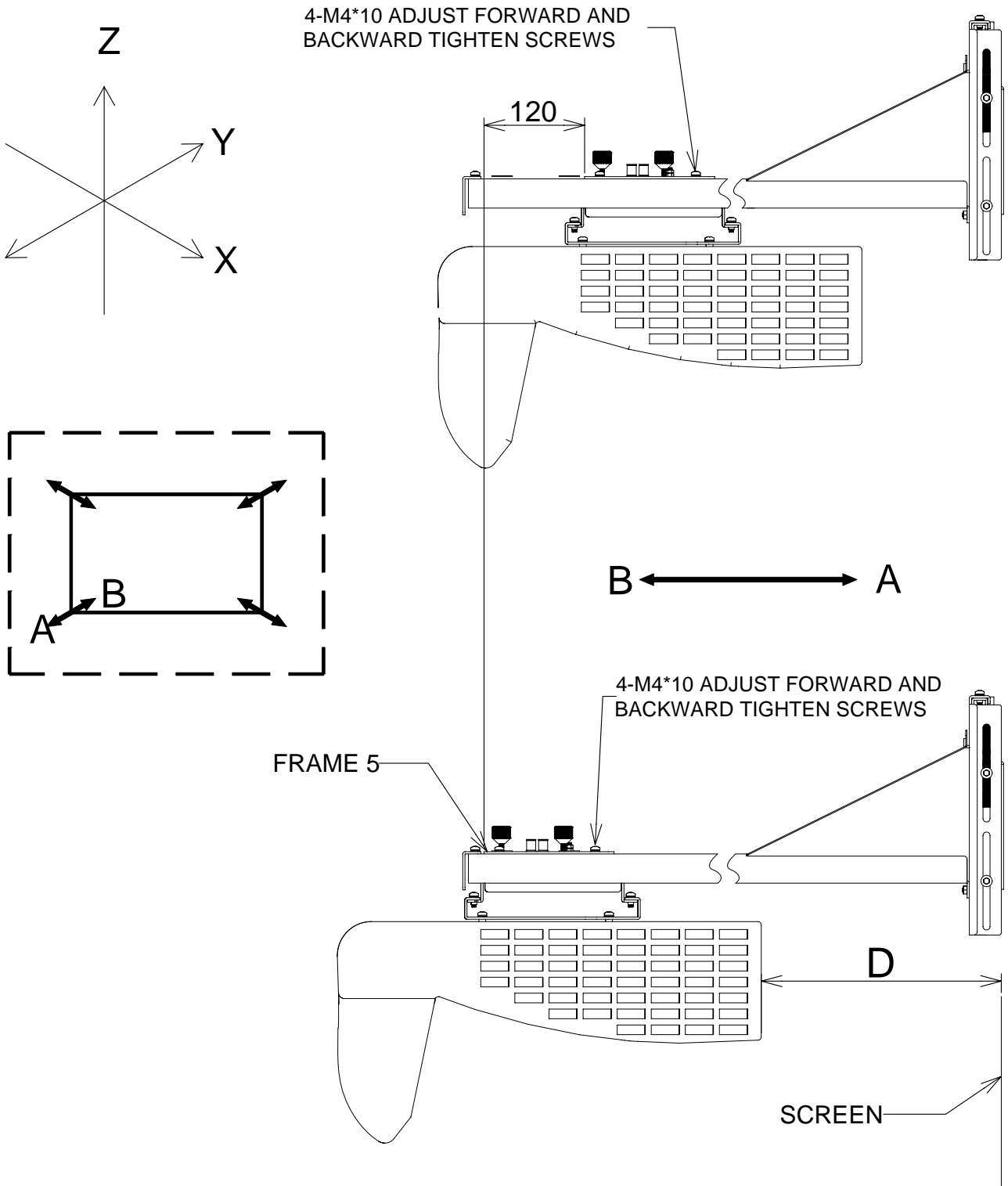

ADJUSTING STEP 6

Instruction of image up and down adjustment movement:

- 1: Loosen screw "B" (4-M4*10mm) slightly. In order to adjust the image's up and down position, turn "M" (up and down adjustment rotation screw) to make sliding structure frame #2 up and down, so as to adjust the image position up and down (Z axis direction).
- 2: Please refer to the projector distance sheet.(P.7) for the highest position of screen to the projector's up and down distance (H1).
- 3: When the image up and down position is well adjusted, tighten screw. "B" (4-M4*10mm)
- 4: The maximum adjustable distance is ± 40 mm.



WARNING

AFTER ALL THE ADJUSTMENT, PLEASE TIGHTEN ALL SCREWS AND NUTS, OTHERWISE, THE PROJECTOR AND WALL MOUNTED BRACKET MAY FALL AND CAUSE PERSONAL INJURY OR PROPERTY LOSS.

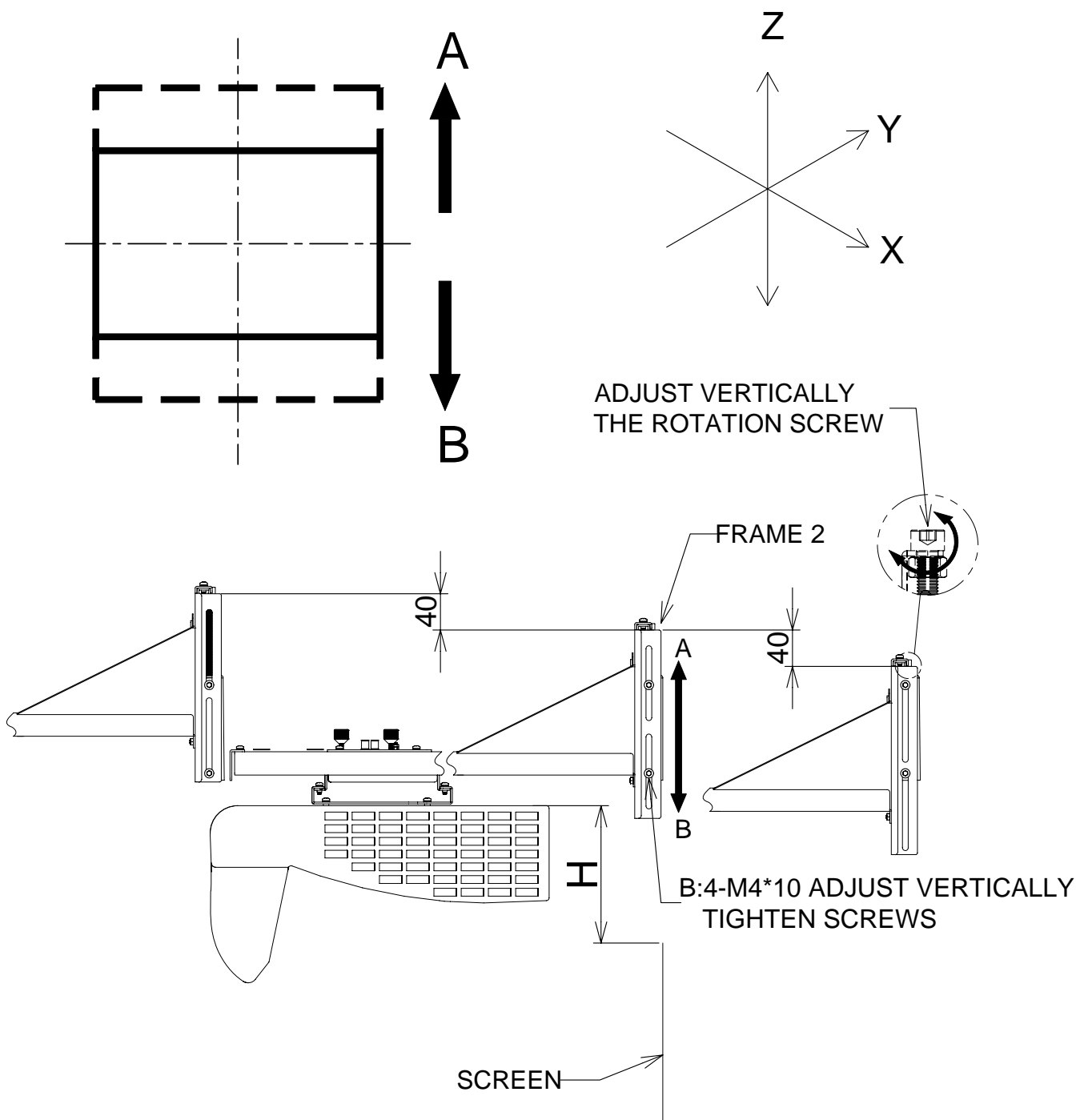



Service

Vivid Color, Vivid Life

○ **Vivitek China**

No. 1090 Century Avenue, Pudong New Area, Shanghai

CIMIC building 18 F zip code 200120

Tel: 86-21-58360088

Fax: 86-21-58360099

<http://www.vivitek.com.cn>

○ **Vivitek EMEA**

Zandsteen 15

2132MZ Hoofddorp

The Netherlands

Tel: +31 20 655 0960

Fax : +31 20 655 0999

E-mail: info@vivitek.eu

Web : www.vivitek.eu